

GBP744D

INSTALLATION TOOL

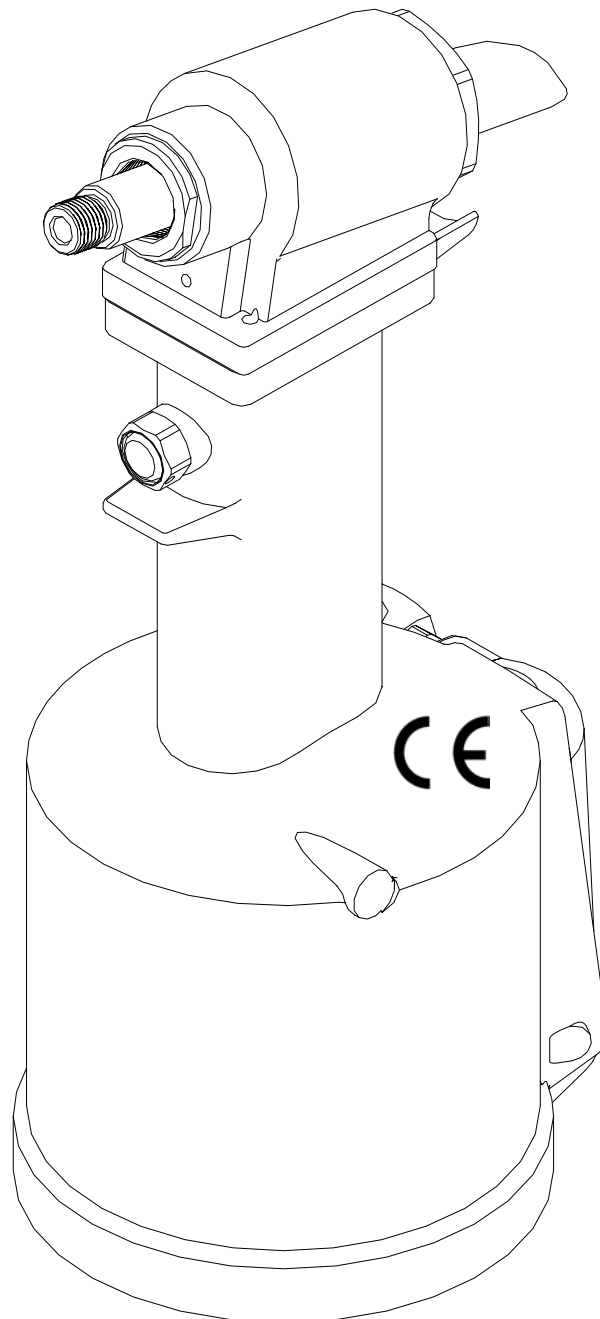

GAGE BILT
MADE IN U.S.A.

GAGE BILT PRODUCTS CORP.

14500 Barber Drive

Warren, Mi 48088

e-mail: solutions@gagebilt.com / www.gagebilt.com

(586) 771-7664

(586) 771-2665 Fax

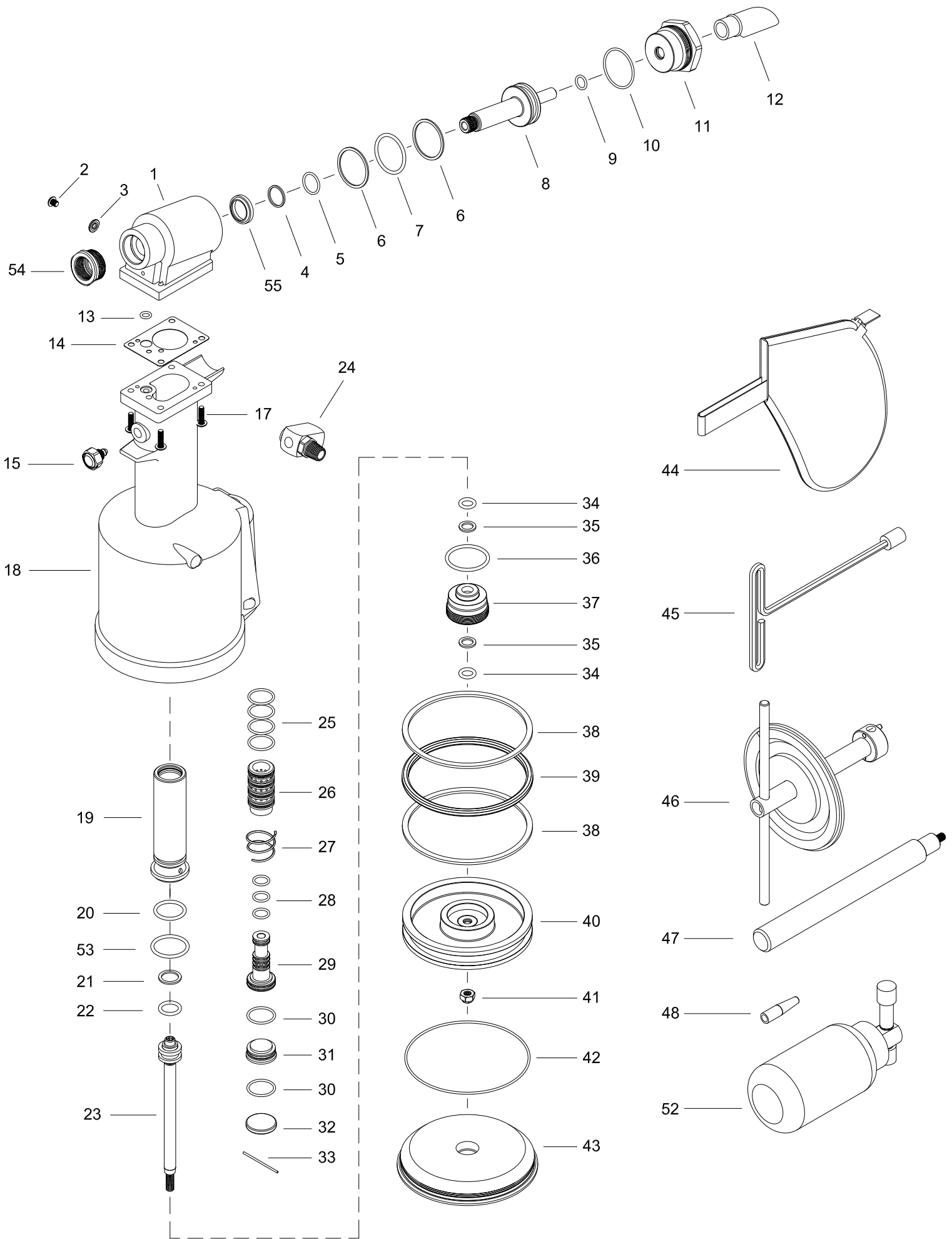

GBP744D Parts List

Ref. No.	Part Number	Description	Qty.
1	744103	Head Cylinder Assembly	1
2*	402482	Button Head Socket Screw	1
3*	S572	Stat-O-Seal	1
4*	401088	Back-Up Ring	1
5*	A-260	O'Ring	1
6	401114	Back-Up Ring	2
7*	A-269	O'Ring	1
8*	744209	Piston	1
9*	S829	O'Ring	1
10*	400792	O'Ring	1
11	744214	Cap	1
12	200232	Deflector	1
13*	S832	O'Ring	1
14*	704129	Gasket	1
15	704130	Trigger Assembly (Inc. 16)	1
16*	400773	O'Ring	1
17*	402479	Buttont Head Cap Screw	4
18	744129	Handle	1
19	743131	Power Cylinder	1
20*	403805	O'Ring	1
21*	S908	Back-Up Ring	1
22*	A-201	O'Ring	1
23	740136	Piston Rod Assembly (Inc. 21 & 22)	1
24	A-249	Swivel	1
25*	400784	O'Ring	4
26	743144	Valve Sleeve	1
27*	744144	Spring	1
28*	400779	O'Ring	3
29	743142	Valve Spool Assembly	1
30*	400785	O'Ring	2
31	744142	Valve Plug	1
32*	744143	Muffler	1
33*	744149	Pin	1
34*	A-287	O'Ring	2
35*	S115	Back-Up Ring	2
36*	A-271	O'Ring	1
37	744118	Packing Plug	1
38*	S909	Back-Up Ring	2
39*	401462	Quad Ring	1
40	744121	Air Piston Assembly	1
41*	400559	Flexlock Nut	1
42*	S12	O'Ring	1
43	744124	Base Cover	1
44**	704214	Stem Catcher Bag	1
45**	704149	Piston Rod Wrench	1
46**	704150	Packing Plug Wrench	1
47**	704151	Power Cylinder Tool	1
48**	704152	Seal Guide	1
49**	S1178	Valve Extractor (Not Shown)	1
50**	744151	Valve Spring Installation Tool (Not Shown)	1
51**	744152	Valve Sleeve Removal Tool (Not Shown)	1
52**	704153	Air Bleeder	1
53*	S892	O'Ring	1
54*	744101	Nose Fitting	1
55*	A-523	Wiper	1

*Service Kit 744009 contains a complete set of O'Rings, Back-Up Rings, Screws and Gaskets.

These items should be kept on hand at all times.

**Ref No. 44-53 are not furnished. 45-52 are recommended for complete tool overhaul.

GBP744D SELECTION CHART

NOSE ASSEMBLY

FASTENER	DIA.	Straight	Right Angle	Offset
CHERRYMAX® ALLMAX® HUCKMAX® HUCK-CLINCH®	1/8 5/32 3/16	456MAX-701-17 ^{1,2} 456MAX-744-20 ¹ 456MAX-749-35 ^{1,2,3}	456MAX-753-54 ^{1,2}	456MAX-763A-43 ^{1,2} 456MAX-744-50OS ¹
MIL-R-7885 NAS9301-9312 BACR15FR/FR BACR15GJ/GK	1/4	08MAX-744-20		08MAX-744-50OS

- 1) ALL THREE DIAMETERS CAN BE INSTALLED WITH ONE NOSE ASSEMBLY.
- 2) NOSE ASSEMBLIES REQUIRE THE 744704 ADAPTER.
- 3) FRONT END EJECTING NOSE ASSEMBLY.
- 4) RIGHT ANGLE NOSE ASSEMBLY MAY REQUIRE MORE THAN 1 PULL.

CHERRYMAX® IS A REGISTERED TRADEMARK OF CHERRY TEXTRON.
 HUCKMAX® & HUCK-CLINCH® ARE A REGISTERED TRADEMARK OF HUCK INT'L. INC.
 ALLMAX® IS A REGISTERED TRADEMARK OF ALLFAST FASTENING SYSTEMS.

GAGE BILT



DECLARATION OF CONFORMITY

WE DECLARE THAT THE EQUIPMENT SPECIFIED HEREIN
CONFORMS TO THE FOLLOWING STANDARDS AND DIRECTIVES.

EN292 part 1 and part 2

ISO 8662 part 1

ISO 3744

COUNCIL DIRECTIVE: 89/392/EEC, 91/368/EEC

93/44/EEC, 93/68/EEC

EQUIPMENT DESCRIPTION:

GBP700 SERIES FASTENER INSTALLATION TOOLS

MANUFACTURER:

GAGE BILT PRODUCTS CORP.

SIGNATURE:

NAME: BRUCE T. GODFREY

CHAIRMAN

WARREN, MI U.S.A.

JUNE 2003

WARRANTY

Seller warrants that all goods covered by this catalog will conform to applicable specifications and will replace, or repair, F.O.B. our plant, any goods providing defective from faulty workmanship, or material, for 90 days from date of shipment.

Said warranty to remain in effect if and only if such goods are used in accordance with all instructions as to maintenance, operation, and use set forth in manuals and instruction sheets furnished by seller.

Sellers obligation under this warranty shall be limited to the repair or rework of the goods supplied or replacement thereof, at Seller's option, and in no case is to exceed the invoice value of said goods. Under no circumstances will seller be liable for incidental or consequential damages or for damages incurred by the buyer or subsequent user in repairing or replacing defective goods or if the goods covered by this warranty are reworked or subjected to any type of additional processing.

This warranty is void if Seller is not notified in writing of any rejections or defects within 90 days after the receipt of the material by the customer.

**THIS WARRANTY IS MADE IN LIEU OF ALL OTHER WARRANTIES,
EXPRESS OR IMPLIED, INCLUDING MERCHANTABILITY.**