

# GBP703D

## INSTALLATION TOOL

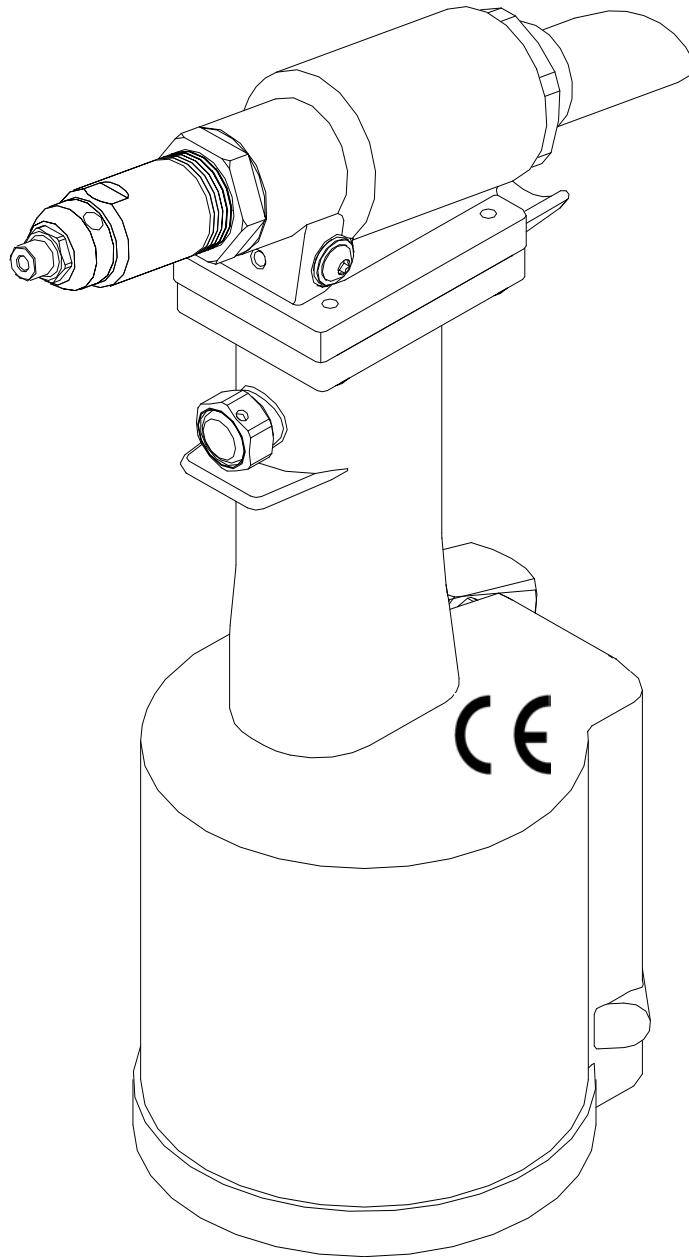

**GAGE BILT**  
MADE IN U.S.A.

**GAGE BILT PRODUCTS CORP.**

14500 Barber Drive

(586) 771-7664

Warren, Mi 48088

(586) 771-2665 Fax

e-mail: [solutions@gagebilt.com](mailto:solutions@gagebilt.com) / [www.gagebilt.com](http://www.gagebilt.com)

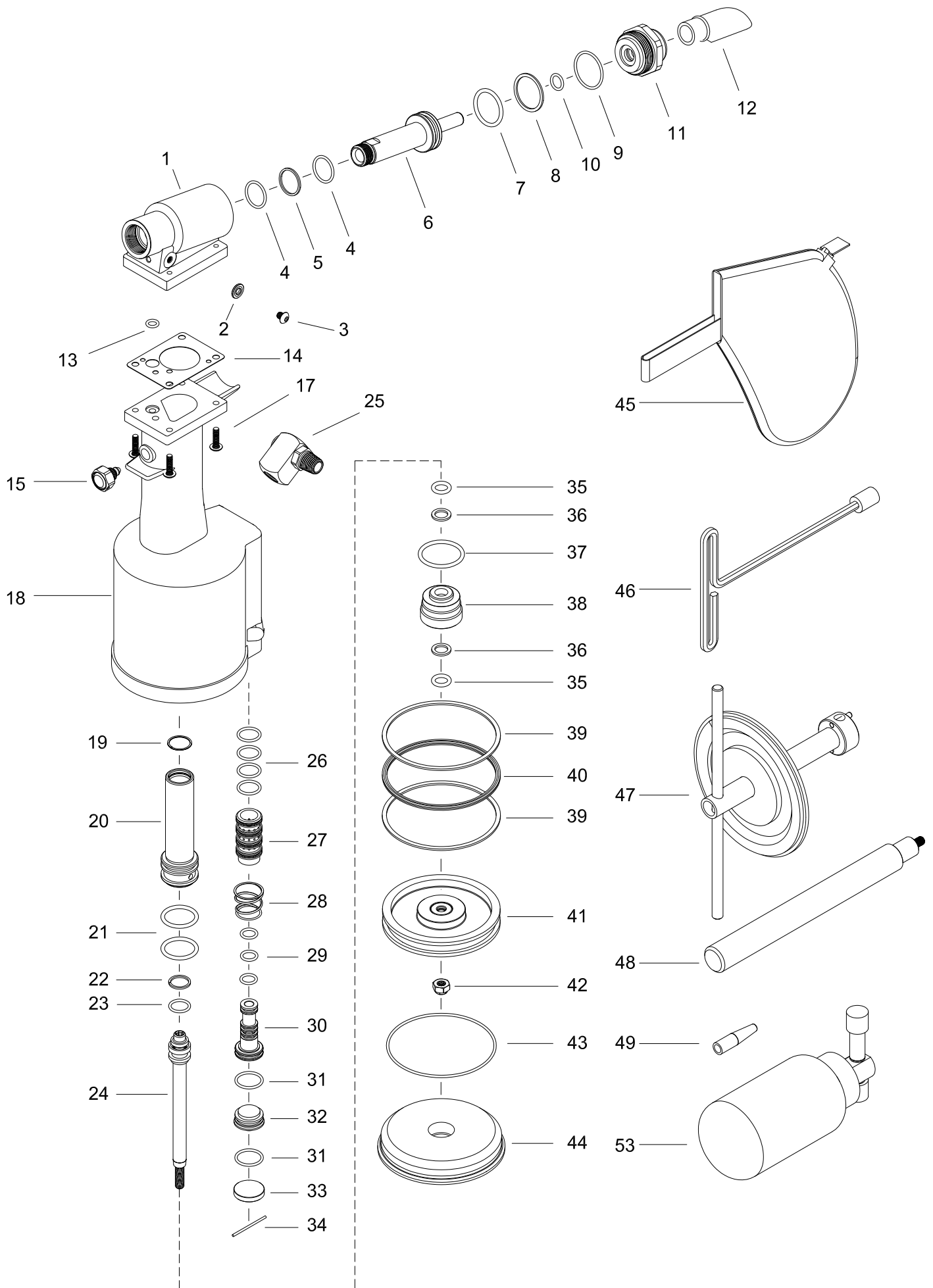

**GBP703D Parts List**

<b>Ref. No.</b>	<b>Part No.</b>	<b>Description</b>	<b>Qty.</b>
1	703109	Head-Cylinder Assembly	1
2*	S572	Stat-O-Seal	1
3*	402482	Button Head Socket Screw	1
4*	S834	O'Ring	2
5*	401089	Back-Up Ring	1
6	703307	Piston	1
7*	405891	O'Ring	1
8*	401110	Back-Up Ring	1
9*	400788	O'Ring	1
10*	S829	O'Ring	1
11	703114	Cap	1
12	200232	Deflector	1
13*	S832	O'Ring	1
14*	704129	Gasket	1
15	704130	Trigger Assy. (Inc. 400773)	1
16*	400773	O'Ring	1
17*	A-928	Button Head Cap Screw	4
18	704132	Handle	1
19*	S734	Retaining Ring	1
20	751131	Power Cylinder	1
21*	403805	O'Ring	2
22*	401102	Back-Up Ring	1
23*	S945	O'Ring	1
24	704138	Piston Rod Assy. (Inc 22 & 23)	1
25	A-249	Swivel	1
26*	400781	O'Ring	4
27	703139	Valve Sleeve	1
28*	704141	Spring	1
29*	400778	O'Ring	3
30	703142	Valve Spool Assembly	1
31*	400783	O'Ring	2
32	704145	Valve Plug	1
33*	704146	Muffler	1
34*	704244	Pin	1
35*	A-287	O'Ring	2
36*	S115	Back-Up Ring	2
37*	405757	O'Ring	1
38	704118	Packing Plug	1
39*	S731	Back-Up Ring	2
40*	S730	Quad Ring	1
41	704121	Air Piston Assembly	1
42*	400559	Flexlock Nut	1
43*	S725	O'Ring	1
44	704125	Base Cover	1
45**	704214	Stem Catcher Bag	1
46**	704149	Piston Rod Wrench	1
47**	704150	Packing Plug Wrench	1
48**	704151	Power Cylinder Tool	1
49**	704152	Seal Guide	1
50**	S1178	Valve Plug Extractor	1
51**	704162	Valve Spring Installation Tool (Not Shown)	1
52**	704163	Valve Sleeve Removal Tool (Not Shown)	1
53**	704153	Air Bleeder	1

\*Service Kit 703023 contains a complete set of O'Rings, Back-Up Rings, Wipers, Screws and Gaskets. These items should be kept on hand at all times.

\*\*Ref. No.45-53 are not furnished with the tool, but are recommended for complete tool overhaul.

## XX-703-18

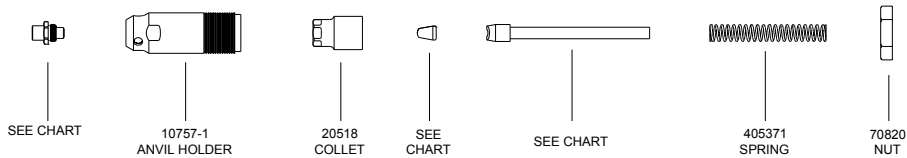

## XX-734-20

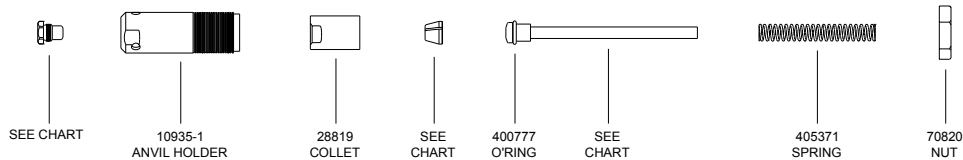

## XX-743-24

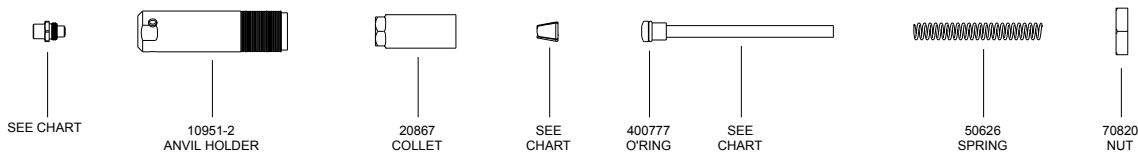

RIVET	DIA.	NOSE ASSEMBLY	NOSE TIP <sup>1</sup>	JAW	FOLLOWER	DESIGNATION
AVEX (1624 PROTRUDING HEAD)	3/16	AV6-743-24 <sup>2</sup>	10141	30824	40820	AV6
AVEX (1624 COUNTERSUNK HEAD)	3/16	6C-743-24 <sup>2</sup>	10141-1	30824	40820	6C
KLAMPITTE (STRUCTURAL) RIVET	3/16	<b>6KT-703-18 <sup>1</sup></b>	<b>10263</b>	<b>30617</b>	<b>40605</b>	<b>6KT</b>
	1/4	8KT-743-24 <sup>2</sup>	10262	30824	40820	8KT
MACHINE SCREW RIVET	5MM	MS5M-703-18 <sup>1</sup>	10332	30617	40605	5MM
MONOBOLT RIVET	3/16	MB06-734A-20 <sup>2,5</sup>	10210	36801	40820	MB06
	1/4 <sup>3</sup>	MB08-734-20 <sup>2,5</sup>	10213	30833	40820	MB08
NUTPLATE RIVET	3/32	<b>4N-703-18 <sup>1</sup></b>	<b>10202</b>	<b>30617</b>	<b>40307</b>	<b>4N</b>
	1/8	<b>5N-703-18 <sup>1</sup></b>	<b>10203</b>	<b>30617</b>	<b>40605</b>	<b>5N</b>
OPEN END CLOSED END NAIL RIVET	3/32	<b>3N-703-18 <sup>1</sup></b>	<b>10247</b>	<b>30617</b>	<b>40307</b>	<b>3N</b>
	1/8	<b>4N-703-18 <sup>1</sup></b>	<b>10202</b>	<b>30617</b>	<b>40307</b>	<b>4N</b>
	5/32	<b>5N-703-18 <sup>1</sup></b>	<b>10203</b>	<b>30617</b>	<b>40605</b>	<b>5N</b>
	3/16	<b>6N-703-18 <sup>1</sup></b>	<b>10204</b>	<b>30617</b>	<b>40605</b>	<b>6N</b>
STAINLESS STEEL OPEN END, CLOSED END NAIL RIVET	1/4 <sup>3</sup>	8Z-743-24 <sup>2</sup>	10211	30824	40820	8Z
	5/32	5SS-743-24	10203	30849	40871	5SS
PLASTIC SPLIT RIVET	3/16	<b>6P-703-18 <sup>1</sup></b>	<b>10167</b>	<b>30617</b>	<b>40605</b>	<b>6P</b>
	1/4	8P-743-24 <sup>2</sup>	10166	30824	40820	8P
T RIVET	3/16	<b>6T-703-18 <sup>1</sup></b>	<b>10209</b>	<b>30617</b>	<b>40605</b>	<b>6T</b>
	1/4 <sup>3</sup>	8T-743-24 <sup>2</sup>	10286	30824	40820	8T
TLR RIVET	1/4	8TLR-743-24 <sup>2</sup>	10246	30617	40820	8TLR

### SELECTION CHART FOR PROTRUDING HEAD ONLY

RIVET	DIA.	NOSE ASSEMBLY	NOSE TIP <sup>1</sup>	JAW	FOLLOWER	DESIGNATION
MULTI-GRIP STRUCTURAL RIVET	3/16	PH6-734A-20 <sup>2,5</sup>	10248	36801	40820	PH6
	1/4 <sup>4</sup>	PH8-734-20 <sup>2,3,5</sup>	10205	30833	40820	PH8

**1) YOU CAN CHANGE THE 703 NOSE ASSEMBLY (INCLUDED WITH TOOL) TO INSTALL OTHER FASTENERS BY PURCHASING NOSE TIP SHOWN AND USING APPROPRIATE FOLLOWER SHOWN.**

2) NOSE ASSEMBLIES WITH A 743 DESIGNATION, I.E. 8Z-743-24, MUST BE ORDERED AS COMPLETE NOSE ASSEMBLY.

3) ALUMINUM RIVET STEEL MANDREL ONLY (100 PSI REQUIRED FOR ALL 1/4" STEEL RIVETS).

4) 1/4" ALUMINUM ONLY.

5) NOSE ASSEMBLIES WITH A 734 DESIGNATION, I.E. PH6-734-20, ARE FOR SERRATED STEM RIVETS ONLY. IF YOU ARE PULING BOTH SMOOTH AND SERRATED STEM RIVETS YOU MUST ORDER THE NOSE ASSEMBLY WITH A 743 DESIGNATION, I.E. MGL06-743-24.

NOTE: THE LAST 2 DIGITS OF THE NOSE ASSEMBLY REPRESENTS THE LENGTH THE NOSE EXTENDS FROM THE TOOL. I.E. -20 = 2.0 INCHES

# GAGE BILT



## DECLARATION OF CONFORMITY

WE DECLARE THAT THE EQUIPMENT SPECIFIED HEREIN  
CONFORMS TO THE FOLLOWING STANDARDS AND DIRECTIVES.

EN292 part 1 and part 2  
ISO 8662 part 1  
ISO 3744  
COUNCIL DIRECTIVE: 89/392/EEC, 91/368/EEC  
93/44/EEC, 93/68/EEC

EQUIPMENT DESCRIPTION:  
GBP700 SERIES FASTENER INSTALLATION TOOLS

MANUFACTURER:  
GAGE BILT PRODUCTS CORP.

SIGNATURE: 

NAME: BRUCE T. GODFREY  
CHAIRMAN  
WARREN, MI U.S.A.  
JUNE 2003

### WARRANTY

Seller warrants that all goods covered by this catalog will conform to applicable specifications and will replace, or repair, F.O.B. our plant, any goods providing defective from faulty workmanship, or material, for 90 days from date of shipment.

Said warranty to remain in effect if and only if such goods are used in accordance with all instructions as to maintenance, operation, and use set forth in manuals and instruction sheets furnished by seller.

Sellers obligation under this warranty shall be limited to the repair or rework of the goods supplied or replacement thereof, at Seller's option, and in no case is to exceed the invoice value of said goods. Under no circumstances will seller be liable for incidental or consequential damages or for damages incurred by the buyer or subsequent user in repairing or replacing defective goods or if the goods covered by this warranty are reworked or subjected to any type of additional processing.

This warranty is void if Seller is not notified in writing of any rejections or defects within 90 days after the receipt of the material by the customer.

**THIS WARRANTY IS MADE IN LIEU OF ALL OTHER WARRANTIES, EXPRESS OR IMPLIED, INCLUDING MERCHANTABILITY.**