

Genesis® nG2-S Hydro Pneumatic Split Tool

71401 Series

Features

- Split tool for breakstem rivets
- Lightweight placing head
- Remote intensifier
- Quick release nose assembly and stem collector
- Vacuum air supply shut-off on trigger
- Enhanced tool life
- Soft touch rubber grip on handle

Benefits

- Reduces operator fatigue
- High placement speed
- Robust tool
- Reduced setting times and change of equipment
- Minimized air consumption
- Reduced time to empty stem collector
- Places a wide range of fasteners
- Ergonomic

Specifications

Head weight (without nose equip.)	1.0 kg
Head weight (min. with equip.)	1.2 Kg
Pull force @ 5.5 bar	10.88 kN
Stroke (min.)	17 mm
Cycle time (approx.)	1 sec
Air supply pressure	5- 7 bar
Free air volume @ 5.5 bar	3.6 litres
Noise level	<75 dB(A)
Vibration	<2.5m/s ²
Intensifier ratio	44:1

Placing capability

Up to 4.8mm (3/16") breakstem rivets.
Can also place Avseal® II sealing plug up to 7 mm.



Dimensions (mm)

Scrap view showing bottle stem collector short version

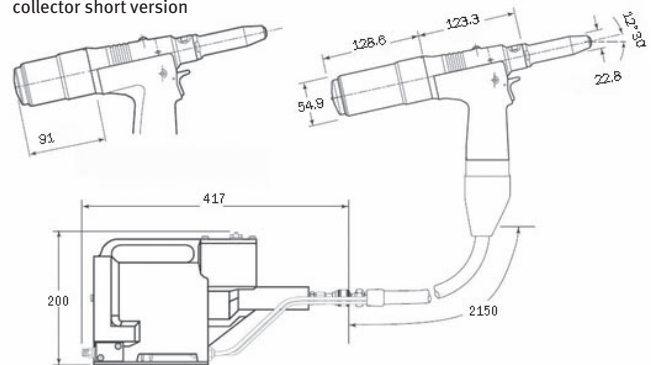

An Acument™ Global Technologies Company

Avdel USA LLC
614 NC Highway 200 South
Stanfield, North Carolina 28163
Tel. +1 704 888-7100 · Fax -0258
infoAvdel-USA@acument.com

www.avdel-global.com

Avdel Canada, a Division of
Acument Canada Limited
87 Disco Road
Rexdale, Ontario M9W 1M3
Tel. +1 416 67906-22 · Fax -78
infoAvdel-Canada@acument.com

© 2007 Acument Intellectual Properties, LLC

Avseal® and Genesis® are trademarks of Avdel UK Limited.

01.2007

Data shown is subject to change without prior notice as a result of continuous product development and improvement policy.
Your local Avdel representative is at your disposal should you need to confirm latest information.